

Mobile unit B 4-1

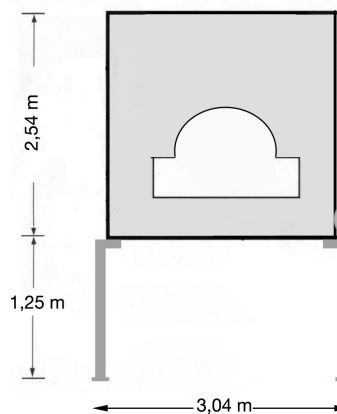

Caractéristiques et dimensions

Construction	Self-contained mobile unit
Centrifuge	Two phases, co-current
Type	B 4-1
Material	High-strength steel
Nominal capacity	60 m ³ /h
Electric power required	90 kW a 380 V, 50 Hz
Start	Star-triangle
Electric plug	63 amperes Cetact, 5 poles
Electric frame	Automatic/manual
Water usage	Sometimes for inner cleaning
Water inlet	1 ½" male screw pipe
Sludge inlet	3" ou 4" mâle screw pipe
Max. distance for plugs	25 mètres
Polymer unit	Liquid or powder
Evacuation pump	Mono pump for water outlet
Sludge pump	Feeding and thickened sludges
Flow meter	On sludge pump and flocculant pump
Timer	On sludge pump and centrifuge
Weight	15 Tn

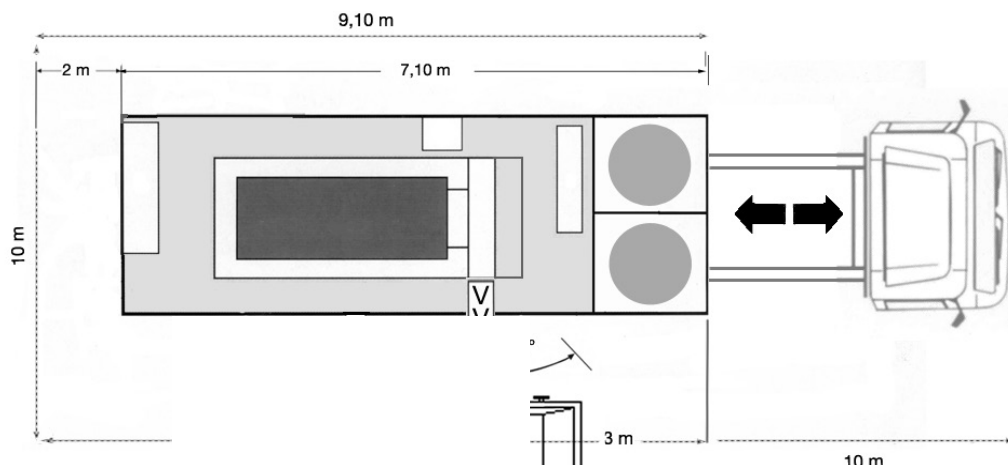

Minimum space for truck exit: 8 m.

Operating surface should be flat, paved and with at least 100 m² of free space.