

Mobile plant S 5-1

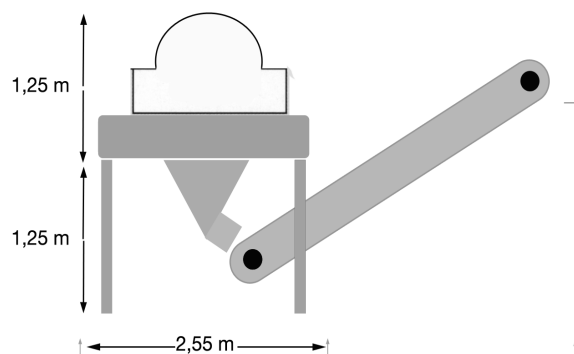

Technical specifications

Construction	Self supported structure
Centrifuge	Two phases, co-current
Type	S 5-1
Material	High performance steel
Nominal capacity	90 m ³ per hour
Electric power required	160 kW a 380 V, 50 Hz (300 KVA)
Start	Triangle-star
Electric plug	Direct with 200 amp protection, 5 poles
Electric frame	Automatic/manual
Water usage	6.000 liters/h a 2-3 bars pression
Water inlet	1 ½ " screw pipe
Sludge inlet	3 " screw pipe
Max. distance of plugs	25 meters
Polymer unit	Liquid or powder
Tanks	1 x 4.000 liters
Shakers	3 x 0,5 kW
Flow meter	For sludge and flocculant
Timer	Hydraulic pump unit and sludge pump
Conveyor band	6 meters
Weight	18 Tn

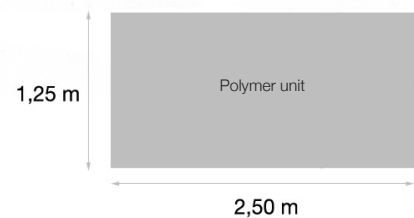
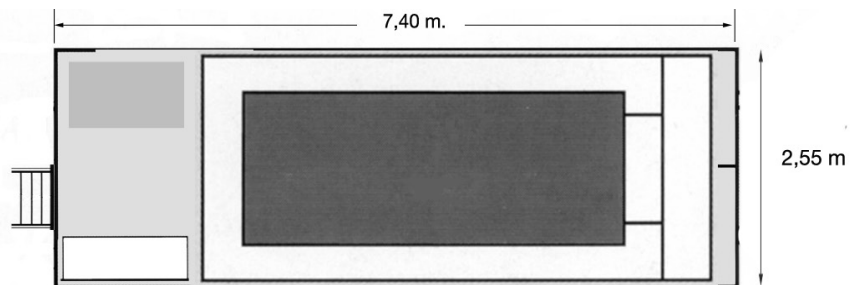

Truck exit minimum space required: 8 mts.

Operating surface should be flat, paved and at least with 100 m² free space